

September 11, 2006

LÖWER – MultiMaster LZ 3

The LÖWER MultiMaster series of profile sanders is a multi-sided sander designed for the finish sanding and denibbing of profiles and mouldings. Sanding strip units process all surfaces and profiles. The MultiMaster series is available to two working widths, 150mm and 300mm (6" or 12").

Additional features include:

- A total of three sanding units
- Automatic height adjustment with digital readout
- Conveyor belt feed with spring loaded hold down rollers
- Constant passline height
- Completely enclosed machine frame
- Dust extraction outlets
- Variable spindle speeds
- Initial set of sanding heads and strips
- Side heads easily adjustable in height and angle

Available options include:

- Infinitely variable feed speed, 4 – 20 m/min (12 – 60 fpm)
- Electronic digital display
- A blowing device for cleaning the workpiece at the end of the machine
- Antistatic brush strip device

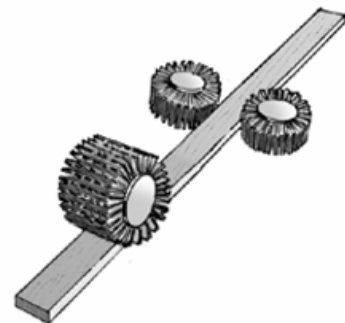



The inside of an LZ 3 with belt feed, hold down rollers and tilted heads shown left. Side heads shown right.

Technical Data:

working width	150 or 300mm (6" or 12")
Max. thickness of work piece	100 mm (4")
Motors top units	0.75 KW (1 HP)
Motors side units	0.37 KW (1/2 HP)
Spindle speeds	200 – 1,000 RPM
Feed belt speed	6, 11 & 16 m/min (18, 33 & 48 ft/min)
Feed motor	1.2 KW (1.6 HP)
Power	460 Volt, 3PH, 60 Hz
Pneumatic	6 bar (85 psi)

US standards in measurement are an approximation